

SY125 Lens Ultra wide - Multi Megapixel - No Distortion



- ❖ **Ultra wide** field of view sees the complete image while the operator can digitally pan-tilt-zoom (dPTZ)
- ❖ Patented Linear Optical Technology™ enables a rectilinear lens with very **low distortion** for maximum resolution
- ❖ Supports **multi megapixel** resolution cameras for demanding applications
- ❖ **Pan focus** keeps near and far objects continuously in focus without lens adjustment
- ❖ Available with CS-mount or C-mount and with auto or manual iris



 LINEAR OPTICAL TECHNOLOGY

Lenses	SY125M	SY125A	MY125M
Mount type	CS-mount		C-mount
Focal length	1.28mm		
Linear Optical Technology®	Yes (note: this technology causes the image to be flipped)		
Distortion	<3%		
Resolution	Up to 5MPix		
F/#	F/1.8 to close		
Sensor size	1/4"	1/3"	1/2.5" *
Field of view (H)	109°	125°	135°
Field of view (V)	93°	109°	119°
Field of view (D)	122°	137°	141°

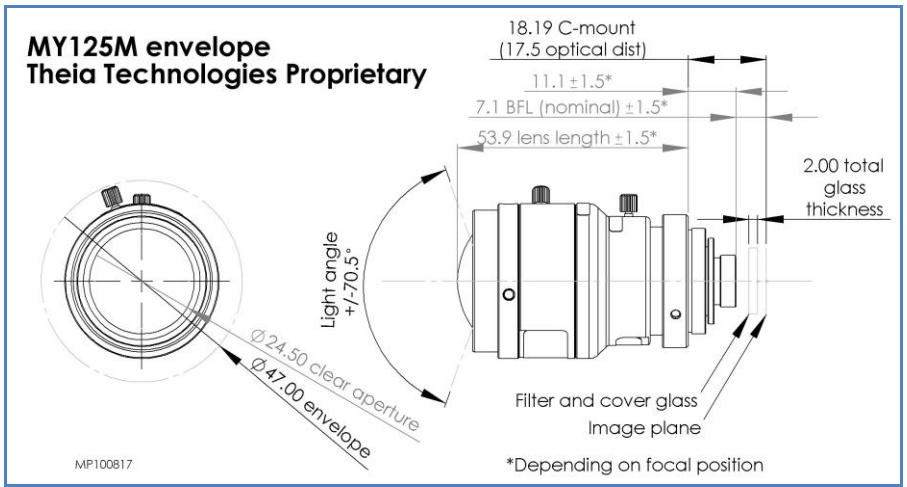
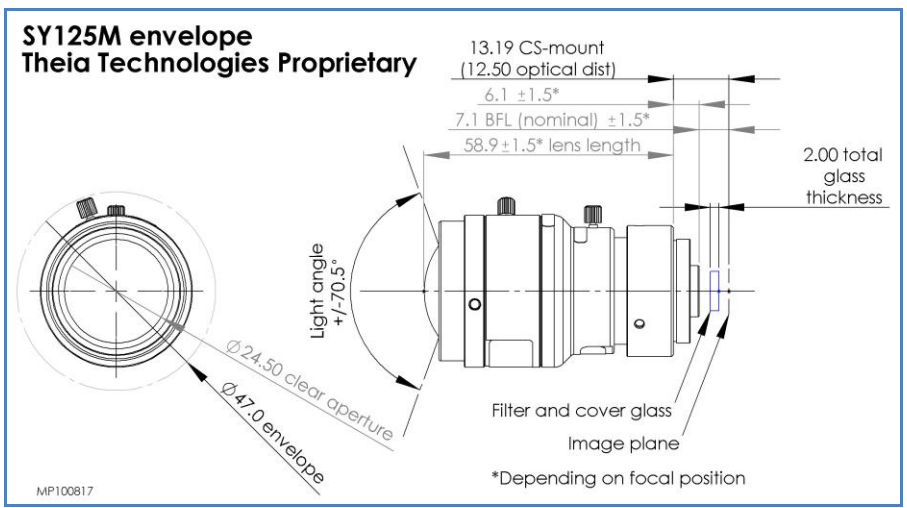
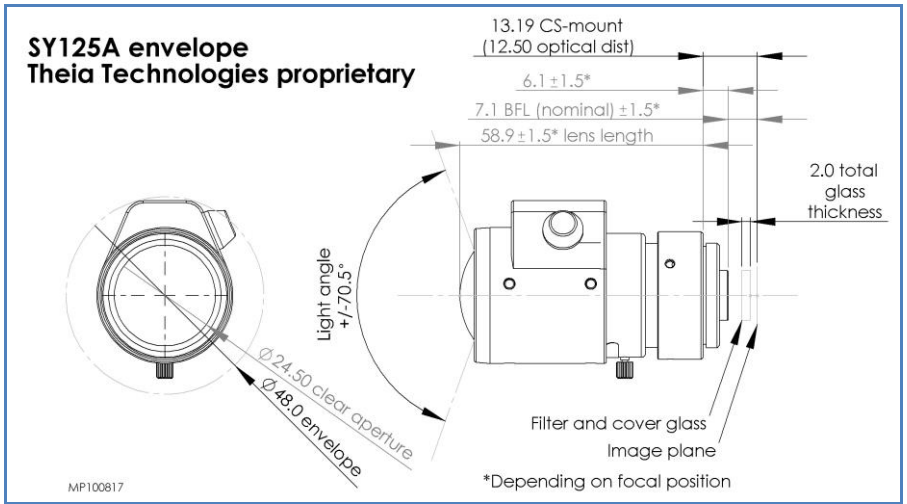

For further information contact: **Theia Technologies**
 info@TheiaTech.com
www.TheiaTech.com
 Phone: 503-570-3296